



IESNA LM-80-2008

MEASURING LUMEN MAINTENANCE OF LED LIGHT SOURCES

MEASUREMENT AND TEST REPORT For

Hongli Zhihui Group Co.,Ltd. Guangzhou Branch
Room 316, Building 2, No.1, Xianke Yi Road, Huadong Town, Huadu District, Guangzhou, China

Model: HL-EMC-3030D46W-2C-S1-HR3

Report Type: 9000 Hours Test Report	Product Type: LED Package
Test Engineer: Daniel Duan	<i>Daniel Duan</i>

Report Number: RSZ201012502-10

	10-13
Reviewed By:	Blake Zhang / EE Engineer
Test Facility:	Test facility was located at No.69,Pulongcun ,Puxinhu Industrial Area, Tangxia , Dongguan, Guangdong, China.
Prepared By:	Bay Area Compliance Laboratories Corp. (Dongguan). No.69,Pulongcun ,Puxinhu Industrial Area, Tangxia , Dongguan, Guangdong, China. Tel: +86-0769-86858888 Fax:+86-0769-86858588
Accreditation:	The IAS Accreditation Number TL-460.

FINAL

1 - GENERAL INFORMATION

1.1 Description of LED Light Sources

Devices tested

#Brand Name:	Hongli
#Part Number:	HL-EMC-3030D46W-2C-S1-HR3
#Part Name:	3030
#Part Type:	LED Package
#Nominal CCT:	3000K
#Power:	1.02W
#Average Current Density per LED die:	726.56mA/mm ²
#Average Power Density per LED die:	2.4703W/mm ²
#CRI:	80
#Die Spacing:	0.22mm

Note:

- The applicant Hongli Zhihui Group Co.,Ltd. Guangzhou Branch declare that their products with model HL-EMC-3030D46W-2C-S1-HR3 are the same to the products in report#R2DG140930052-10-9000-M1 and is authorized by original applicant to use their test data.
- All the data in previous report (R2DG140930052-10-9000-M1) is shared in this report.

1.2 Standards Used:

- x IESNA LM-80-08: IES Approved Method for Measuring Lumen Maintenance of LED Light Sources.
- x ENERGY STAR® Requirements for the Use of LM-80 Data (This standard was not accredited by IAS)

1.3 Test Facility

The testing facility used by Bay Area Compliance Laboratories Corp. (Dongguan). is located at No.69, Pulongcun, Puxinhu Industry Area, Tangxia, Dongguan, Guangdong, China

1.4 Description of Auxiliary Equipment

Device	Manufacture	Model No	Serial No	Test Range	Calibration date	Calibration due date
Integral Sphere	EVERFINE	Diameter 0.3m	1011119	380-780nm, Diameter:0.3m ,0-1999Lumen	2015-03-25	2016-03-25
Programmable Test Power for LEDs	EVERFINE	LED300E	1008002	15V/2000mA	2015-03-05	2016-03-05
High accuracy array spectroradiometer	EVERFINE	HAAS-2000	1012016T	380-780nm	2015-03-25	

1.8 Sample Set

Sampling Method:

LED samples for IESNA LM-80 testing consist of units built from a minimum of three manufacturing lots with each manufacturing lot built from different wafer lots built on non-consecutive days. These manufacturing lots are picked to represent a wide parametric distribution. Each Sample is soldered to all of the reliability stress boards for a given set of IESNA LM-80 tests.

Sample Size:

Total 50Pcs;

Each Ts test condition 25Pcs

The samples tested at Ts 85 °C and Ts 105 °C were received at 2014-09-30 and tested during 2014-11-06 to 2015-12-09. The samples were numbered from 1 to 25 and 26 to 50

Data Set 1: 85 °C,150mA

Part Number:	HL-EMC-3030D46W-2C-S1-HR3
Number of Units:	25
Actual Case Temperature(T_S):	$T_S = 84.6 \text{ }^\circ\text{C}$
Actual Ambient Temperature(T_A):	$T_A = 82.2 \text{ }^\circ\text{C}$
Life Test Drive Current:	$I_F = 150\text{mA}$
Measurement Current:	$I_F = 150\text{mA}$

Data Set 2: 105 °C, 150mA

Part Number:	HL-EMC-3030D46W-2C-S1-HR3
Number of Units:	25
Actual Case Temperature(T_S):	$T_S = 104.3 \text{ }^\circ\text{C}$
Actual Ambient Temperature(T_A):	$T_A = 103.4 \text{ }^\circ\text{C}$
Life Test Drive Current:	$I_F = 150\text{mA}$
Measurement Current:	$I_F = 150\text{mA}$

3 - Test Data

3.1 Data Set 1, 85 °C, 150mA (Lumen Maintenance)

No.	V _F (V)		Lumen Maintenance (%)								
	0hr(Initial)		1000hrs	2000hrs	3000hrs	4000hrs	5000hrs	6000hrs	7000hrs	8000hrs	9000hrs
1	6.348	118.2	100.25	99.83	99.41	98.98	98.31	97.63	97.21	97.04	96.62
2	6.375	116.9	99.57	99.49	99.06	98.12	97.69	96.92	96.41	96.07	95.47
3	6.115	117.6	100.34	100.34	100.17	99.32	98.64	98.04	97.45	97.19	96.85
4	6.111	118.7	99.75	99.58	99.16	98.57	97.81	97.14	96.88	96.46	96.21

3.3 Data Set 2, 105 °C, 150mA (Lumen Maintenance)

No.	V _F (V)		Lumen Maintenance (%)								
	0hr(Initial)		1000hrs	2000hrs	3000hrs	4000hrs	5000hrs	6000hrs	7000hrs	8000hrs	9000hrs
26	6.125	119.7	99.42	99.16	98.66	97.99	97.41	96.32	95.74	95.15	94.57
27	6.352	116.9	99.83	99.06	98.80	98.20	97.52	96.66	95.64	95.30	94.78
28	6.086	119.9	99.83	99.17	98.75	98.17	97.33	96.58	95.66	95.08	94.83
29	6.294	115.3	99.91	99.83	99.13	98.53	97.83	96.88	96.01	95.32	94.97
30	6.294	117.0	99.23	98.89	98.21	97.78	97.18	96.24	95.21	94.62	94.19
31	6.349	118.4	99.41	98.99	98.40	97.64	96.79	96.20	95.10	94.51	94.00
32	6.090	119.4	98.91	98.66	98.16	97.82	97.15	96.31	95.73	95.31	94.81
33	6.308	114.5	99.91	99.04	98.52	97.73	97.12	96.77	96.33	95.81	95.37
34	6.333	117.6	99.57	99.15	98.72	98.04	97.19	96.77	96.17	95.92	95.49
35	6.097	119.3	100.08	99.25	98.99	98.41	97.74	96.90	96.56	96.31	95.89
36	6.100	119.3	99.83	99.92	99.41	98.83	98.16	97.65	96.48	96.23	95.56
37	6.082	120.2	99.67	99.75	99.17	98.42	97.92	97.50	97.34	96.84	95.34
38	6.293	117.3	100.09	100.34	100.00	99.40	98.47	98.38	98.12	97.78	97.19
39	6.253	115.6	100.09	99.83	99.13	98.70	97.92	97.15	96.89	95.85	95.16
40	6.342	114.7	99.65	99.65	99.22	98.87	98.17	97.30	96.77	96.08	95.38

Appendix A EUT PHOTO

A.1 #Mechanical Dimensions (Ta = 25 °C)

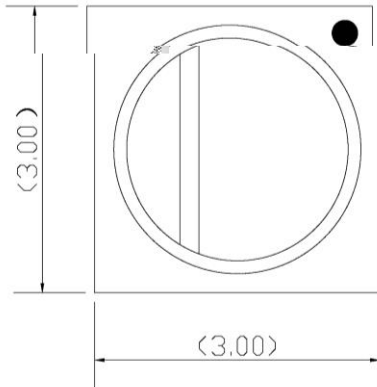

All dimensions are in millimeter

A.2 EUT Photo

